

Summer Two in Year 6

English

We are reading...

In English, we will be reading "Wonder" by R. J. Palacio.

We will explore the themes within the text, in particular we'll discuss disability and starting new schools.

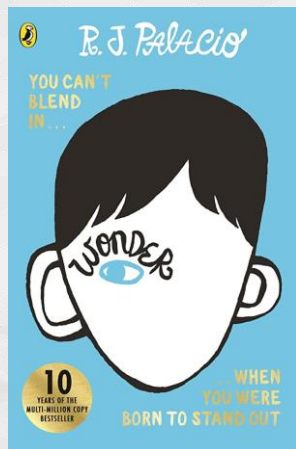

Maths

We will consolidate our learning and complete maths investigations.



Science

Electricity

We will study electricity and electrical circuits.

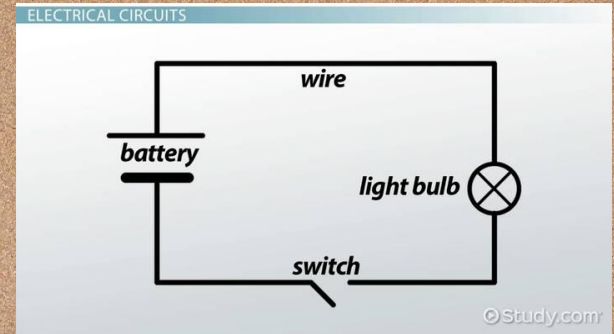

DT

Gears and Pulleys

The children will design a fairground carousel ride, using pulleys and gears.



Geography

We will be learning about Ordnance Survey maps and collecting data. We will apply this knowledge to our local area.



Purple Mash - Computing

- Unit 6.8 - Binary
- Unit 6.9 - Spreadsheets (Google Sheets)
- Moving On - Transition to Secondary School

Music & Drama

We will be learning our end of year production!



Purple Mash - 2Be Safe Online

We will be learning various units relating to:

- * Online relationships
- * Managing online information
- * Privacy and security

French

We will be learning the following units:

- Unit 7: Le Week-end
- Unit 8: Les vêtements
- Unit 9: Ma journée
- Unit 10: Les transports
- Unit 11: Le Sport
- Unit 12: On va faire la fête.



PSHE

“Changing Me”

- Self-image
- Body image
- Puberty and feelings
- Conception to birth
- Reflections about change
- Physical attraction
- Respect and consent
- Boyfriends/girlfriends
- Sexting

[JIGSAW lessons](#) - RSE Human reproduction lesson 3- Conception & birth

Transition

We will talk about our secondary schools and prepare ourselves for the change ahead.

Primary

Secondary